

# North Ayrshire Branch

# New Year Ball

St Matthew's Academy, 5<sup>th</sup> January 2024

|                     |  |  |                  |                  |
|---------------------|--|--|------------------|------------------|
| <b>NEW YEAR JIG</b> |  |  | <b>8x32 J</b>    |                  |
|                     |  |  | 1 3<br><b>RA</b> | 2 1<br><b>LA</b> |

Maureen Robson, 1995, RSCDS Book 51

3C/4C longwise set.

|                          |  |  |  |                 |  |
|--------------------------|--|--|--|-----------------|--|
| <b>THE CASTLE OF MEY</b> |  |  |  | <b>8x32 R</b>   |  |
| Inveran Reels<br>        |  |  |  | 1 2<br><b>P</b> |  |

John Walton, 2012, RSCDS QE Diamond Jubilee

3C/4C longwise set.

|                          |  |                             |               |             |  |
|--------------------------|--|-----------------------------|---------------|-------------|--|
| <b>WIND ON LOCH FYNE</b> |  |                             | <b>3x32 S</b> |             |  |
|                          |  |                             |               |             |  |
|                          |  | ALL<br><b>T<sub>B</sub></b> |               | finish:<br> |  |

John Bowie Dickson, 1986, Dunedin 1, RSCDS Thirty Popular Dances Vol 2

3C/3C triangular set.

|                               |  |                        |                                 |               |  |
|-------------------------------|--|------------------------|---------------------------------|---------------|--|
| <b>THE GALLOPING CAROUSEL</b> |  |                        |                                 | <b>4x32 J</b> |  |
| 1 2 3 4<br><b>RA</b>          |  | 4x 2 3 1x<br><b>RA</b> |                                 |               |  |
|                               |  |                        | 2 4 1 3<br><b>T<sub>R</sub></b> |               |  |

John de Chastelain, 25 Dances for 25 Years

4C/4C longwise set

|                       |                  |   |                  |                             |                                 |  |
|-----------------------|------------------|---|------------------|-----------------------------|---------------------------------|--|
| <b>TARTAN RAINBOW</b> |                  |   |                  |                             | <b>3x32 S</b>                   |  |
| <p><b>S</b></p>       | <p><b>RA</b></p> | <p><b>S<sub>↑</sub> T<sub>B</sub></b></p> | <p><b>LA</b></p> | <p><b>X<sub>R</sub></b></p> | <p>1 2 3</p> <p><b>KNOT</b></p> |  |

Sue Peyt, Tartan Rainbow Book

3C/3C longwise set

|                               |  |                 |                 |                             |  |
|-------------------------------|--|-----------------|-----------------|-----------------------------|--|
| <b>THE MONTGOMERIES' RANT</b> |  |                 |                 | <b>8x32 R</b>               |  |
| <p><b>X<sub>R</sub></b></p>   |  | <p><b>S</b></p> | <p><b>S</b></p> | <p><b>X<sub>R</sub></b></p> |  |

Castle Menzies, 1749, RSCDS Book 10.1

3C/4C longwise set.

|                             |  |                             |                             |                             |   |  |
|-----------------------------|--|-----------------------------|-----------------------------|-----------------------------|---|--|
| <b>SETON'S CEILIDH BAND</b> |  |                             |                             |                             | <b>4x64 J</b>   |  |
| <p><b>X<sub>R</sub></b></p> |  | <p><b>X<sub>R</sub></b></p> |                             | <p><b>X<sub>R</sub></b></p> | <p><b>B T<sub>R</sub><sup>3/4</sup></b></p>                   |  |
| <p><b>B</b></p>             |  | <p><b>X<sub>L</sub></b></p> | <p>1x 3</p> <p><b>R</b></p> | <p>1 4</p> <p><b>R</b></p>  | <p>2x 3x 4x 1x</p> <p><b>T<sub>R</sub>1<sup>1/2</sup></b></p> |  |

Bruce Fordyce, Morison's Bush Collection

4C/4C longwise set.

INTERVAL

# CITY LIGHTS

8x32 J

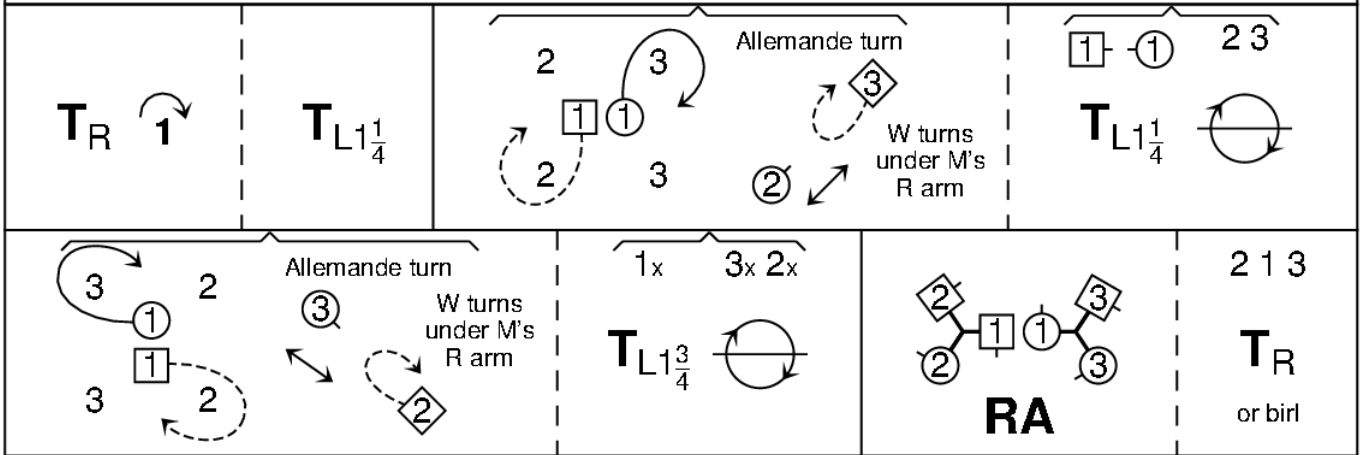

Nicola Scott, 2015, RSCDS Book 52.1

3C/4C longwise set.

# GREENMANTLE

3x32 S

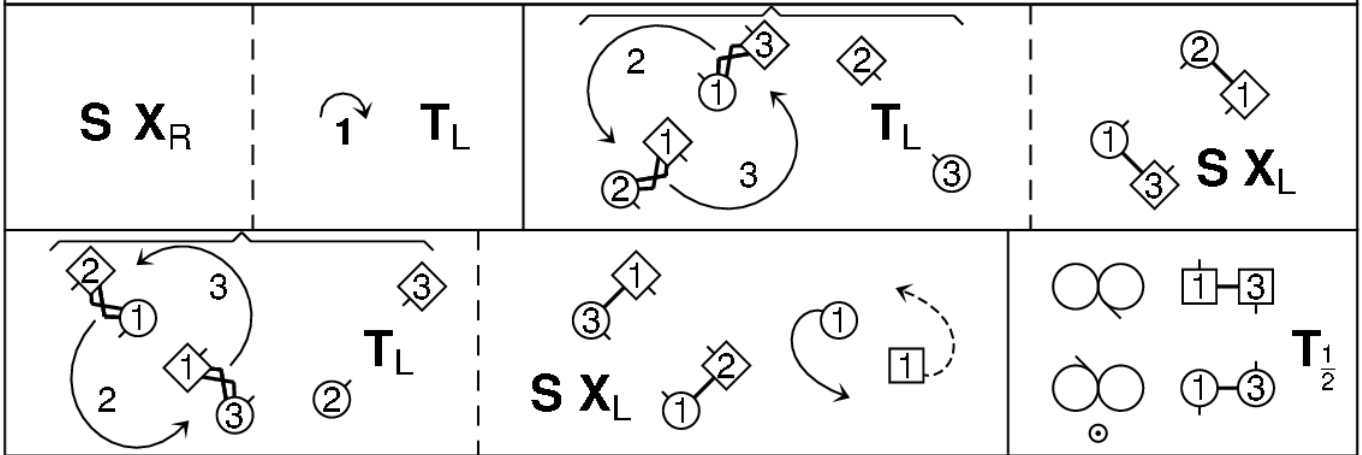

John Wilkinson, 2004

3C/3C longwise set.

# STAIRCASE IN STYRIA

5x40 R

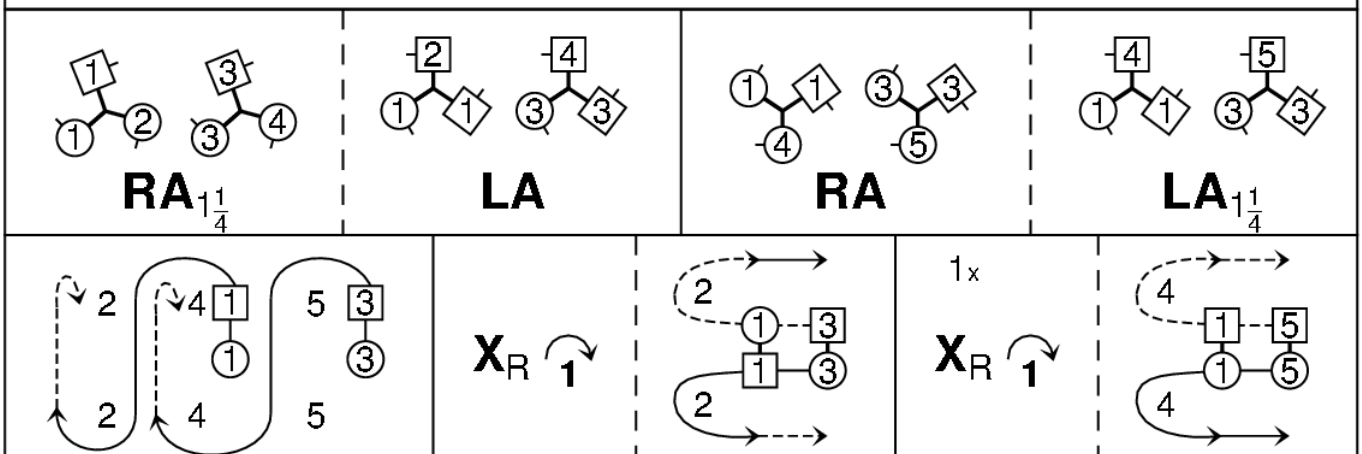

Margaret Gray, CD booklet of The Sunday Class Book 2

5C/5C longwise set.

# NEIL M GRANT

8x32 J

|         |  |              |  |  |  |
|---------|--|--------------|--|--|--|
| $X_R$ 1 |  | Spoke<br>    |  |  |  |
|         |  | 3x 1x 2x<br> |  |  |  |

Christine Grant, 2012, RSCDS Book 49.1

3C/4C longwise set.

# THE BON VIVEUR

2x32 S + 2x32 R

|   |     |                       |                        |
|---|-----|-----------------------|------------------------|
| 8 |     | Schiehallion Reel<br> | ALL<br>                |
|   | 4 4 | 12 bars               | T <sub>R</sub><br>Bird |

Ian Brockbank, 2015, RSCDS Book 52.11

4C/4C square set.

# C'EST L'AMOUR or THE FLIRT

8x32 J

|   |   |   |                         |
|---|---|---|-------------------------|
|   |   |   |                         |
| S | S | S | S                       |
|   |   |   | 2 1 3<br>T <sub>R</sub> |

Lowes, 1830, RSCDS Book 34.1

3C/4C longwise set.

# TAMBOURINE

8x32 R

|                 |  |  |  |  |            |
|-----------------|--|--|--|--|------------|
| → to 2 1 3<br>← |  |  |  |  | 2 1 3<br>6 |
|-----------------|--|--|--|--|------------|

Lawrie Bowlen, East Ivanhoe Bk

3C/4C longwise set

# EXTRAS

|                             |                     |   |   |   |                        |
|-----------------------------|---------------------|---|---|---|------------------------|
| <b>GOOD HEARTED GLASGOW</b> |                     |   |   |   | <b>8x32 J</b>          |
| $T_R$ 1 ↻                   | $T_{L1\frac{1}{4}}$ | $\overbrace{2 \boxed{1} \textcircled{1} 3}$<br><b>RA RA</b> | $\overbrace{2 \textcircled{1} \boxed{1} 3}$<br><b>LA LA</b> | ↔ | 2 1 3<br>○<br><b>6</b> |

Peter Knapman, 1988, Collins Pocket Reference

3C/4C longwise set.

|   |  |  |                    |               |   |
|---|--|--|--------------------|---------------|---|
| <b>THE IRISH ROVER</b>                            |  |  |                    |               | <b>8x32 R</b>   |
| $\boxed{1}$ 2 ↘ 3<br>N<br>$\textcircled{1}$ 2 ↗ 3 | $\textcircled{2}$ $\boxed{1}$ $\textcircled{1}$ $\textcircled{3}$<br><b>RA</b> |  | $T_{L\frac{3}{4}}$ | $3x$ $2x$<br> | $3 \textcircled{1} \textcircled{2}$   $\textcircled{3} \textcircled{1} 3$<br>$\textcircled{3} \textcircled{1} 2$   $2 \textcircled{1} \textcircled{2}$<br><b>RL</b> <b>RL</b> |

James B Cosh, 22 SCDs, RSCDS Thirty Popular Dances Vol 2

3C/4C longwise set.